



I

- 1 Centralina elettronica di controllo con modulo allarmi.
- 2 Tipo di espansione: valvola termostatica.
- 3 Predisposizione in morsettiera del quadro elettrico per il collegamento del micro porta.
- 4 Tutti i compressori sono dotati di resistenza di preriscaldamento del carter.
- 5 I compressori semiermetici sono protetti mediante termistore; i modelli dotati di pompa dell'olio vengono ulteriormente protetti mediante un pressostato differenziale per l'olio.
- 6 Nelle unità per la bassa e polivalente temperatura con R22, i compressori semiermetici sono dotati di dispositivo elettronico per il controllo della temperatura del gas compresso.
- 7 I compressori con volume spostato fino a 52 m³/h sono ad avviamento diretto, per potenze superiori l'avviamento è di tipo part-winding.
- 8 Tutte le unità sono dotate di pressostato di minima regolabile. Le unità che montano compressori con volume spostato inferiore a 90m³/h sono dotate di pressostato di massima regolabile a riarmo automatico. Le unità che montano compressori con volume spostato uguale o superiore a 90m³/h sono dotate di doppio pressostato regolabile a riarmo manuale. Le soluzioni adottate sono conformi alle prescrizioni previste dalla Direttiva 97/23/CE "Attrezzature in pressione".
- 9 Indicatore di liquido e solenoide linea liquido su tutte le unità.
- 10 Tutte le unità sono dotate di ricevitore di liquido conforme alle prescrizioni previste dalla Direttiva 97/23/CE "Attrezzature in pressione".
- 11 Scambiatore di calore di tipo coassiale.
- 12 Pressostato di comando dei ventilatori per il controllo della condensazione presente su tutte le unità. Su richiesta, il controllo della condensazione può essere effettuato mediante variatore elettronico della velocità dei ventilatori.
- 13 Interruttori di sicurezza sui portelli del lato condensante.
- 14 Pannello remoto: viene fornito già collegato all'unità mediante un cavo di lunghezza 5 metri (variabile secondo richiesta fino a 20 metri).
- 15 Scarico acqua di condensa a perdere.
- 16 Resistenza nello scarico condensa nelle unità in media, bassa, polivalente temperatura e nelle unità di congelamento.
- 17 Installazione a parete cella con foro per il tampone.
- 18 Resistenze attorno al bocchaglio delle ventole evaporatore nelle unità di congelamento.

❖ **Optionals:**

- a **Tensione diversa.**
- b **Condensazione ad acqua;** le unità provviste di questa dotazione sono munite di valvola barostatica per il controllo della condensazione e, nelle unità in bassa temperatura, di ventole per il raffreddamento del compressore.
- c **Monitor di tensione.**
- d **Variatore di velocità ventole condensatore.**
- e **Quadro elettrico riscaldato.**
- f **Resistenze bocchaglio ventilatore evaporatore** (escluso i modelli IDC/IDX).

JK

- 1 Electronic control panel with alarm module.
- 2 Expansion device: thermal expansion valve.
- 3 Terminal board inside the switchboard pre-arranged for the connection to a door switch.
- 4 All compressors provided with crankcase heater.
- 5 Semi-hermetic compressors are protected by thermistors; models equipped with oil pump are further protected by a differential oil pressure switch.
- 6 On low temperature and multi-temperature units on R22, semi-hermetic compressors are equipped with an electronic device controlling the discharge temperature of the refrigerant.
- 7 Compressors with a displacement up to 52 m³/h are provided with direct start, those with higher capacity are equipped with part winding start.
- 8 All units are equipped with an adjustable low pressure switch. Units equipped with compressors whose displacement is smaller than 90 m³/h are provided with an adjustable high pressure switch with automatic reset. Units equipped with compressors whose displacement is equal to or larger than 90 m³/h are provided with an adjustable double pressure switch with manual reset. This outfit complies with the provisions of the "Pressure Equipment Directive" 97/23/EC.
- 9 Sight glass and liquid line solenoid valve on all units.
- 10 All units are equipped with a liquid receiver complying with the provisions of the "Pressure Equipment Directive" 97/23/EC.
- 11 Coaxial type heat exchanger.
- 12 Condenser fan pressure switch on all units. On request condenser fan control by means of an electronic fan speed regulator.
- 13 Safety switches on the front doors of the condensing section.
- 14 Remote panel: already connected to the unit and provided with a 5 metres long cable (on request extension up to 20 metres).
- 15 Direct drainage of condensate.
- 16 Drain heater on all medium temperature, low temperature, multi-temperature and blast-freezing units.
- 17 Through-the-wall installation.
- 18 Standard evaporator fan cowl heater(s) on all blast freezing units.

❖ **Optionals:**

- a **Special voltage.**
- b **Water-cooled condenser:** units equipped with water-cooled condenser are also provided with a pressure controlled water valve controlling the condensation; low temperature units are also provided with a compressor cooling fan.
- c **Voltage monitor.**
- d **Condenser fan speed regulator.**
- e **Switchboard heater.**
- f **Evaporator fan cowl heater(s)** (standard on IDC/IDX models).

D

- 1 Elektronische Steuerung mit Alarmmodul.
- 2 Einspritzsystem: thermostatisches Expansionsventil.
- 3 In der Schaltschrank-Klemmleiste ist der Anschluß für den Tür-Mikroschalter vorgesehen.
- 4 Alle Verdichter sind mit Ölsumpfheizung ausgerüstet.
- 5 Die halbhermetischen Verdichter sind durch einen Thermistor geschützt. Die mit Ölpumpe ausgerüsteten Modelle werden zusätzlich durch einen Öldifferenz-Druckschalter geschützt.
- 6 Bei den Tiefkühlaggregaten und bei den Mehrzweckgeräten (Normal- und Tiefkühlung) mit R22 Kältemittel sind die halbhermetischen Verdichter mit einer elektronischen Druckgastemperaturkontrolle ausgerüstet.
- 7 Für die Verdichter mit einem bis 52m³/h Hubvolumen ist ein Direktanlauf vorgesehen, während die für höhere Leistungen in Part-Winding geschaltet werden.
- 8 Alle Aggregate sind mit einstellbarem Niederdruck-Pressostat ausgerüstet. Die Aggregate, an denen Verdichter mit einem niedrigeren als 90m³/h Hubvolumen eingebaut werden, sind mit einstellbarem Hochdruck-Pressostat mit automatischer Rückstellung ausgestattet. Die Aggregate, an denen Verdichter mit einem gleichen oder höheren als 90m³/h Hubvolumen eingebaut werden, sind mit einstellbarem Doppelpressostat mit manueller Rückstellung ausgerüstet. Die gewählten Lösungen erfüllen die Vorschriften der Richtlinie 97/23/EG über "Druckgeräte".
- 9 Schauglas und Magnetventil an der Flüssigkeitsleitung bei allen Geräten.
- 10 Alle Aggregate sind mit Flüssigkeitssammler gemäß den Vorschriften der Richtlinie 97/23/EG über "Druckgeräte" ausgerüstet.
- 11 Koaxialwärmeaustauscher.
- 12 Verflüssigerlüfter-Pressostat bei allen Aggregaten. Auf Anfrage kann die Kontrolle des Verflüssigungsdrucks durch einen elektronischen Drehzahlregler für die Verflüssigerlüfter ausgeführt werden.
- 13 Sicherheitsschalter an den Fronttüren des Verflüssigungssatzes.
- 14 Fernschalttafel schon mit einem 5m langen Verbindungskabel geliefert. Das Kabel kann auf Anfrage bis auf 20 m verlängert werden.
- 15 Direkter Tauwasserablauf.
- 16 Tauwasserablaufheizung bei den Aggregaten für Normal- und Tiefkühlung, sowie bei den Mehrzweckgeräten (Normal- und Tiefkühlung) und den Geräten für Schockkühlung.
- 17 Wandstopfergerät, Ausschnitt für den Stopfer erforderlich.
- 18 Serienmäßige Heizelemente für Verdampferlüfterhaube bei allen Geräten für Schockkühlung.

☛ Zubehör:

- a **Sonderspannung.**
- b **Wassergekühlter Verflüssiger:** wassergekühlte Geräte werden mit Kühlwasserregler ausgestattet. Überdies wird ein Lüfter für die Verdichterkühlung bei den Geräten für Tiefkühlung eingebaut.
- c **Spannungsmonitor.**
- d **Drehzahlregler für die Verflüssigerlüfter.**
- e **Schaltschrankheizung.**
- f **Heizelemente für Verdampferlüfterhaube** (außer den Modellen IDC/IDX).

E

- 1 Centralita electrónica de control con módulo alarmas.
- 2 Tipo de expansión: válvula termostática.
- 3 Predisposición en el tablero de bornes del cuadro eléctrico para la conexión del micro de puerta.
- 4 Todos los compresores están dotados de resistencia de precalentamiento del carter.
- 5 Los compresores semihérméticos están protegidos mediante un termistor; los modelos dotados de bomba del aceite están además protegidos por medio de un presóstato diferencial para el aceite.
- 6 En las unidades para baja temperatura y en las unidades polivalentes con gas refrigerante R22, los compresores semiherméticos están dotados de dispositivo electrónico para el control de la temperatura del gas comprimido.
- 7 Los compresores con desplazamiento hasta 52m³/h son de arranque directo, para potencias superiores el arranque es de tipo part-winding.
- 8 Todas las unidades están provistas de presóstato de mínima regulable. Las unidades, en las cuales se instalan compresores con desplazamiento inferior a 90m³/h, se suministran con presóstato de máxima regulable de rearme automático. Las unidades, en las cuales se instalan compresores con desplazamiento igual o superior a 90 m³/h, están provistas de presóstato doble regulable de rearme manual. Las soluciones adoptadas cumplen los requisitos de la Directiva 97/23/CE sobre "Equipos a presión".
- 9 Visor de líquido y solenoide línea líquido en todas las unidades.
- 10 Todas las unidades están provistas de recipiente de líquido conforme a los requisitos de la Directiva 97/23/CE sobre "Equipos a presión".
- 11 Cambiador de calor coaxial.
- 12 Presóstato de mando de los ventiladores para el control de la condensación presente en todas las unidades. Bajo pedido, el control de la condensación puede ser efectuado mediante un variador electrónico de la velocidad de los ventiladores.
- 13 Interruptores de seguridad sobre las puertas de la unidad condensadora.
- 14 Panel remoto: se suministra ya conectado a la unidad mediante un cable de longitud 5 m (variable bajo pedido hasta 20 m).
- 15 Descarga del agua de condensación al exterior.
- 16 Resistencia en el tubo de desagüe del condensado en las unidades de media y baja temperatura, en las unidades polivalentes y en aquellas de congelación.
- 17 Instalación en la pared de la cámara con orificio para el tampón.
- 18 Resistencias en torno a la tobera del ventilador del evaporador en las unidades de congelación.

☛ Opciones:

- a **Tensión diferente.**
- b **Condensación por agua:** las unidades provistas de esta dotación se suministran con válvula presostática para el control de la condensación y, en las unidades de baja temperatura, con ventilador para el enfriamiento del compresor.
- c **Monitor de tensión.**
- d **Variador de velocidad ventilador condensador.**
- e **Cuadro eléctrico calefaccionado.**
- f **Resistencias tobera ventilador evaporador** (a excepción de los modelos IDC/IDX).

R404A

Ti	+5/+15°C	IDA 120	IDA 150	IDA 170	IDA 200	IDA 220	IDA 300	IDA 320	IDA 301
		1	1	1	2	2	3	3	3
	V/ph/Hz	400/3/50	400/3/50	400/3/50	400/3/50	400/3/50	400/3/50	400/3/50	400/3/50
	kW	1,92	2,47	2,22	3,74	3,45	5,59	5,16	6,13
		E	E	S	E	S	E	S	E
	m³/h 50 Hz	4,51	6,63	6,75	9,37	8,47	11,81	12,17	14,9
	m³/h 60 Hz	5,05	6,31	6,36	10,03	9,25	11,83	11,86	14,17
		AR	AR	AR	AR	AR	AR	AR	AR
	kW	0,14	0,14	0,14	0,28	0,28	0,75	0,75	0,75
	kg	1,6	2	2	6	6	11	12	13

CONDENSATORE • CONDENSER • VERFLÜSSIGER • CONDENSADOR • CONDENSEUR • КОНДЕНСАТОР

	mm	3,2	3,2	3,2	3,2	3,2	3,2	3,2	3,2
	n°xØ mm	1x350	1x350	1x350	2x350	2x350	1x500	1x500	1x500
	n°xW	1x140	1x140	1x140	2x140	2x140	1x540	1x540	1x540
	m³/h	2450	2450	2450	4800	4800	6450	6450	6450

EVAPORATORE • EVAPORATOR • VERDAMPFER • EVAPORADOR • EVAPORATEUR • ИСПАРИТЕЛЬ

	mm	7	7	7	7	7	7	7	7
	n°xØ mm	1x350	1x350	1x350	2x350	2x350	1x500	1x500	1x500
	n°xW	1x140	1x140	1x140	2x140	2x140	1x750	1x750	1x750
	m³/h	2700	2700	2700	5200	5200	8300	8300	8300
	m	13	13	13	14	14	20	20	20

TABELLA DI SELEZIONE • SELECTION TABLE • AUSWAHLTABELLE

TABLA DE SELECCION • TABLEAU DE SÉLECTION • ТАБЛИЦА ВЫБОРА

Ti	Ta	Q _o (W)	V (m³)	Q _o (W)	V (m³)	Q _o (W)	V (m³)	Q _o (W)	V (m³)	Q _o (W)	V (m³)	Q _o (W)	V (m³)	Q _o (W)	V (m³)	Q _o (W)	V (m³)
+5°C	20°C	3170	54,3	4305	85,4	4375	86,8	6625	138	6455	134	8105	175	7975	172	10265	249
	32°C	2500	36,4	3270	56	3550	60,8	5335	95,2	5050	90,1	6280	119	6350	120	7910	172
	43°C	1940	28,3	2435	40	2690	44,2	4100	70,6	3700	63,7	4560	85,7	4765	89,6	5705	120
+10°C	20°C	3870	63,1	5340	99,8	5365	100	7685	153	7770	155	9975	212	9700	206	12655	295
	32°C	3090	47,7	4135	70,5	4205	71,6	6295	116	6265	116	7850	157	7810	156	9915	223
	43°C	2335	37,1	3160	54,7	3280	56,7	4980	93,6	4670	87,8	5825	121	5945	123	7315	169
+15°C	20°C	4680	82,2	5960	114	6300	121	8965	171	9280	178	12135	251	11695	242	15415	347
	32°C	3775	67,8	4910	94,8	5170	99,8	7530	147	7685	150	9675	206	9500	202	12245	287
	43°C	2890	51,4	3825	69,4	4085	74,2	5910	112	5815	110	7300	151	7320	151	9200	215

R404A

Ti: +5÷+15°C	IDA 400	IDA 420	IDA 500	IDA 520	IDA 750	IDA 770	IDA 1000	IDA 1020	IDA 1500
	4	4	4	4	5	5	5	5	5
V/ph/Hz	400/3/50	400/3/50	400/3/50	400/3/50	400/3/50	400/3/50	400/3/50	400/3/50	400/3/50
kW	7,94	6,7	9,9	9,38	11,61	11,28	14,22	12,66	18,48
	E	S	E	S	E	S	E	S	S
m³/h 50 Hz	18,74	17,53	23,63	23,37	29,8	26,5	37,49	38,64	48,8
m³/h 60 Hz	17,88	17,69	22,49	21,04	28,36	28,04	35,76	-	46,37
	AR	AR	AR	AR	AR	AR	AR	AR	AR
kW	0,9	0,9	0,9	0,9	1,5	1,5	1,5	1,5	1,5
kg	13	13	12,5	12,5	20	20	25	25	24

CONDENSATORE • CONDENSER • VERFLÜSSIGER • CONDENSADOR • CONDENSEUR • КОНДЕНСАТОР

mm	3,2	3,2	3,2	3,2	3,2	3,2	3,2	3,2	3,2
n°xØ mm	2x450	2x450	2x450	2x450	2x500	2x500	2x500	2x500	2x500
n°xW	2x390	2x390	2x390	2x390	2x540	2x540	2x540	2x540	2x540
m³/h	9800	9800	9800	9800	12900	12900	12900	12900	12900

EVAPORATORE • EVAPORATOR • VERDAMPFER • EVAPORADOR • EVAPORATEUR • ИСПАРИТЕЛЬ

mm	7	7	7	7	7	7	7	7	7
n°xØ mm	2x450	2x450	2x450	2x450	2x500	2x500	2x500	2x500	2x500
n°xW	2x450	2x450	2x450	2x450	2x750	2x750	2x750	2x750	2x750
m³/h	11400	11400	11400	11400	16600	16600	16600	16600	16600
m	19	19	19	19	22	22	22	22	22

TABELLA DI SELEZIONE • SELECTION TABLE • AUSWAHLTABELLE

TABLA DE SELECCION • TABLEAU DE SÉLECTION • ТАБЛИЦА ВЫБОРА

Ti	Ta	Q _o (W)	V (m³)	Q _o (W)	V (m³)	Q _o (W)	V (m³)	Q _o (W)	V (m³)	Q _o (W)	V (m³)	Q _o (W)	V (m³)	Q _o (W)	V (m³)	Q _o (W)	V (m³)	Q _o (W)	V (m³)
+5°C	20°C	13100	315	12235	294	14600	486	14070	469	16690	516	18415	569	20715	678	27740	908	36570	1190
	32°C	10185	221	9800	212	11275	333	11230	332	12980	382	14635	431	15805	483	21955	671	28940	903
	43°C	7430	158	7410	158	8155	235	8450	243	9465	267	10960	309	11255	330	16355	480	21565	669
+10°C	20°C	16085	366	14830	337	17980	570	17090	542	20495	610	22405	666	25630	792	33810	1044	44575	1424
	32°C	12695	296	12000	280	14115	426	13780	416	16180	479	18005	533	19930	615	27075	835	35695	1096
	43°C	9450	230	9190	224	10435	331	10515	333	12040	379	13685	430	14560	470	20495	662	27020	796
+15°C	20°C	19530	457	17830	417	21880	640	20570	601	24885	735	27010	798	31315	897	40815	1169	53810	1627
	32°C	15610	385	14545	359	17410	526	16735	505	19890	623	21910	686	24725	713	33010	952	43520	1231
	43°C	11810	316	11270	301	13105	437	12925	431	15050	463	16865	518	18430	549	25330	755	33390	946

R404A

Ti	-5/+5°C	IDN 120	IDN 150	IDN 170	IDN 200	IDN 220	IDN 201	IDN 221	IDN 300	IDN 320	IDN 301	IDN 321	IDN 400	IDN 420
		1	1	1	1	1	2	2	2	2	3	3	3	3
	V/ph/Hz	400/3/50	400/3/50	400/3/50	400/3/50	400/3/50	400/3/50	400/3/50	400/3/50	400/3/50	400/3/50	400/3/50	400/3/50	400/3/50
	kW	1,68	2,23	2,22	2,67	2,89	3,39	3,59	4,29	4,43	5,65	5,58	6,86	6,14
		E	E	S	E	S	E	S	E	S	E	S	E	S
	m³/h 50 Hz	4,51	6,63	6,75	8,36	8,47	9,37	9,88	11,81	12,17	14,9	14,74	18,74	16,76
	m³/h 60 Hz	5,05	6,31	6,36	7,96	8,1	10,03	10,16	11,83	11,86	14,17	14,6	17,88	17,69
		ER	ER	ER	ER	ER	ER	ER	ER	ER	ER	ER	ER	ER
	kW	3,1	3,1	3,1	3,1	3,1	3,85	3,85	3,85	3,85	7,6	7,6	7,6	7,6
	kg	1,5	1,5	1,5	1,5	1,5	6	6	6	6	7	11	11	11

CONDENSATORE • CONDENSER • VERFLÜSSIGER • CONDENSADOR • CONDENSEUR • КОНДЕНСАТОР

	mm	3,2	3,2	3,2	3,2	3,2	3,2	3,2	3,2	3,2	3,2	3,2	3,2	3,2
	n°xØ mm	1x350	1x350	1x350	1x350	1x350	2x350	2x350	2x350	2x350	1x500	1x500	1x500	1x500
	n°xW	1x140	1x140	1x140	1x140	1x140	2x140	2x140	2x140	2x140	1x540	1x540	1x540	1x540
	m³/h	2450	2450	2450	2450	2450	4800	4800	4800	4800	6450	6450	6450	6450

EVAPORATORE • EVAPORATOR • VERDAMPFER • EVAPORADOR • EVAPORATEUR • ИСПАРИТЕЛЬ

	mm	7	7	7	7	7	7	7	7	7	7	7	7	7
	n°xØ mm	1x350	1x350	1x350	1x350	1x350	2x350	2x350	2x350	2x350	1x500	1x500	1x500	1x500
	n°xW	1x140	1x140	1x140	1x140	1x140	2x140	2x140	2x140	2x140	1x750	1x750	1x750	1x750
	m³/h	2700	2700	2700	2700	2700	5200	5200	5200	5200	8300	8300	8300	8300
	m	13	13	13	13	13	14	14	14	14	20	20	20	20

TABELLA DI SELEZIONE • SELECTION TABLE • AUSWAHLTABELLE

TABLA DE SELECCION • TABLEAU DE SÉLECTION • ТАБЛИЦА ВЫБОРА

Ti	Ta	Q ₀ (W)	V (m³)	Q ₀ (W)	V (m³)	Q ₀ (W)	V (m³)	Q ₀ (W)	V (m³)	Q ₀ (W)	V (m³)	Q ₀ (W)	V (m³)	Q ₀ (W)	V (m³)	Q ₀ (W)	V (m³)	Q ₀ (W)	V (m³)	Q ₀ (W)	V (m³)						
-5°C	20°C	2145	28,3	3040	40,6	3420	45,7	3715	52,9	3835	63,1	4390	62,5	4490	73,9	5800	96,8	5650	94,3	7310	125	7040	120	8950	170	8605	164
	32°C	1610	19,5	2255	26,7	2635	31,2	2705	35,1	2970	47,4	3290	42,7	3480	55,5	4855	73,3	4795	72,4	5630	90,7	5500	88,6	6910	129	6765	126
	43°C	1120	11,6	1540	17,7	1895	21,8	1800	23,5	2150	32	2285	29,8	2520	37,5	3720	51,3	3735	51,5	3900	63,8	3985	65,2	4440	83,6	4600	86,6
0°C	20°C	2695	37,2	3835	55	4240	60,8	4720	71,3	4740	82,3	5505	83,2	5555	96,4	7235	130	6985	126	9445	173	8785	161	10585	218	9900	203
	32°C	2065	27	2915	40,5	3320	46,1	3535	51,9	3730	67,1	4220	62	4370	78,6	5875	105	5745	103	6890	128	6755	126	8220	178	7915	172
	43°C	1475	16,8	2060	26,7	2435	31,5	2455	36,2	2755	42,9	3020	44,5	3225	50,2	4280	66,2	4260	65,9	4900	87,3	4875	86,9	5585	103	5615	104
+5°C	20°C	3340	49,3	4780	75,2	5215	82	5915	102	5820	120	6830	118	6815	140	8940	183	8575	176	11215	218	10165	198	13100	285	12065	262
	32°C	2605	35,8	3700	54,7	4140	61,3	4530	80,6	4635	91,4	5330	94,8	5430	107	7035	136	6830	133	9115	175	8385	161	10150	222	9605	210
	43°C	1910	24,6	2690	37,8	3095	43,5	3245	53,8	3480	58,9	3905	64,8	4080	69	5205	95,3	5130	93,9	6360	118	6170	115	7270	141	7340	142

R404A

Ti	-5/+5°C	IDN 500	IDN 520	IDN 750	IDN 770	IDN 1000	IDN 1020	IDN 1500	IDN 1520	IDN 2000
		4	4	4	4	5	5	5	5	5
	V/ph/Hz	400/3/50	400/3/50	400/3/50	400/3/50	400/3/50	400/3/50	400/3/50	400/3/50	400/3/50
	kW	8,88	8,68	9,89	9,78	12,97	11,94	16,13	17,18	19,28
		E	S	E	S	E	S	E	S	S
	m³/h 50 Hz	23,63	23,37	29,8	26,5	37,49	38,64	47,25	48,8	56,95
	m³/h 60 Hz	22,49	23,16	28,36	28,04	35,76	39,05	44,99	46,37	58,56
		ER	ER	ER	ER	ER	ER	ER	ER	ER
	kW	10,1	10,1	11,1	11,1	12,1	12,1	16,9	16,9	16,9
	kg	15	15	15	15	20	20	23	23	27

CONDENSATORE • CONDENSER • VERFLÜSSIGER • CONDENSADOR • CONDENSEUR • КОНДЕНСАТОР

	mm	3,2	3,2	3,2	3,2	3,2	3,2	3,2	3,2	3,2
	n°xØ mm	2x450	2x450	2x450	2x450	2x500	2x500	2x500	2x500	2x500
	n°xW	2x390	2x390	2x390	2x390	2x540	2x540	2x540	2x540	2x540
	m³/h	9800	9800	9800	9800	12900	12900	12900	12900	12900

EVAPORATORE • EVAPORATOR • VERDAMPFER • EVAPORADOR • EVAPORATEUR • ИСПАРИТЕЛЬ

	mm	7	7	7	7	7	7	7	7	7
	n°xØ mm	2x450	2x450	2x450	2x450	2x500	2x500	2x500	2x500	2x500
	n°xW	2x450	2x450	2x450	2x450	2x750	2x750	2x750	2x750	2x750
	m³/h	11400	11400	11400	11400	16600	16600	16600	16600	16600
	m	19	19	19	19	22	22	22	22	22

TABELLA DI SELEZIONE • SELECTION TABLE • AUSWAHLTABELLE

TABLA DE SELECCION • TABLEAU DE SÉLECTION • ТАБЛИЦА ВЫБОРА

Ti	Ta	Q _o	V	Q _o	V	Q _o	V	Q _o	V	Q _o	V	Q _o	V	Q _o	V	Q _o	V	Q _o	V
		(W)	(m³)	(W)	(m³)	(W)	(m³)	(W)	(m³)	(W)	(m³)	(W)	(m³)	(W)	(m³)	(W)	(m³)	(W)	(m³)
-5°C	20°C	10445	262	10090	253	11320	295	12485	325	14365	390	17675	480	20240	569	26030	732	27715	778
	32°C	7920	186	7890	185	8550	206	9620	232	10700	281	13615	358	15035	409	20110	547	21350	610
	43°C	5580	106	5770	110	5990	123	6910	142	7355	163	9785	216	10960	253	15290	353	16100	390
0°C	20°C	13070	350	12465	334	14165	399	15485	436	18085	526	21925	638	24415	738	30970	936	34375	1073
	32°C	10110	277	9875	271	10915	309	12120	344	13785	423	17160	526	18505	566	24240	742	26905	865
	43°C	7315	154	7360	155	7860	173	8895	195	9790	230	12595	295	13795	339	18695	459	19750	493
+5°C	20°C	16140	486	15235	459	17530	526	19045	572	22490	687	26960	823	30440	947	38085	1185	42275	1378
	32°C	12685	409	12210	394	13740	420	15110	462	17470	521	21390	638	23540	726	30220	932	33540	1077
	43°C	9380	222	9245	218	10120	252	11300	281	12730	293	15995	368	17055	468	22595	620	25080	726

R404A

Ti	-18÷-25°C	IDK 203	IDK 223	IDK 300	IDK 320	IDK 400	IDK 420	IDK 401	IDK 500
		1	1	1	1	1	1	2	2
	V/ph/Hz	400/3/50	400/3/50	400/3/50	400/3/50	400/3/50	400/3/50	400/3/50	400/3/50
	kW	2,66	3,04	2,53	3,15	3,85	3,41	4,22	5,44
		E	S	E	S	E	S	S	S
	m³/h 50 Hz	11,81	12,17	12,92	14,74	16,73	15,94	17,53	23,37
	m³/h 60 Hz	11,11	11,86	14,17	14,6	15,5	-	17,69	23,44
		ER	ER	ER	ER	ER	ER	ER	ER
	kW	3,1	3,1	3,1	3,1	3,1	3,1	3,85	3,85
	kg	3	3	3	2	3	3	6,5	6

CONDENSATORE • CONDENSER • VERFLÜSSIGER • CONDENSADOR • CONDENSEUR • КОНДЕНСАТОР

	mm	3,2	3,2	3,2	3,2	3,2	3,2	3,2	3,2
	n°xØ mm	1x350	1x350	1x350	1x350	1x350	1x350	2x350	2x350
	n°xW	1x140	1x140	1x140	1x140	1x140	1x140	2x140	2x140
	m³/h	2450	2450	2450	2450	2450	2450	4800	4800

EVAPORATORE • EVAPORATOR • VERDAMPFER • EVAPORADOR • EVAPORATEUR • ИСПАРИТЕЛЬ

	mm	7	7	7	7	7	7	7	7
	n°xØ mm	1x350	1x350	1x350	1x350	1x350	1x350	2x350	2x350
	n°xW	1x140	1x140	1x140	1x140	1x140	1x140	2x140	2x140
	m³/h	2700	2700	2700	2700	2700	2700	5200	5200
	m	13	13	13	13	13	13	14	14

TABELLA DI SELEZIONE • SELECTION TABLE • AUSWAHLTABELLE

TABLA DE SELECCION • TABLEAU DE SÉLECTION • ТАБЛИЦА ВЫБОРА

Ti	Ta	Q _o (W)	V (m³)	Q _o (W)	V (m³)	Q _o (W)	V (m³)	Q _o (W)	V (m³)	Q _o (W)	V (m³)	Q _o (W)	V (m³)	Q _o (W)	V (m³)	Q _o (W)	V (m³)
-18°C	20°C	3075	41,6	2790	37,8	3230	47,1	3670	53,5	4340	68,5	4520	71,3	5170	90,1	7195	146
	32°C	2415	25,7	2295	24,4	2495	33,6	2805	37,8	3325	49	3595	53	4220	70,7	5785	90,3
	43°C	1850	20,4	1685	20,6	1980	23,2	2185	25,6	2560	35,5	2920	40,5	3555	54,9	4595	80,8
-22°C	20°C	2570	30,7	2380	28,4	2790	34,9	3105	38,8	3670	52	3905	55,3	4350	79,2	6295	112
	32°C	1975	18	1935	17,6	2025	22,7	2315	26	2715	37,6	3065	42,5	3610	54,1	4945	82,7
	43°C	1400	14,7	1445	15,2	1475	15,9	1640	17,7	1815	22,7	2240	28	2745	39,3	3670	60,5
-25°C	20°C	2265	25,5	2135	24,1	2355	25,9	2695	29,7	3235	42,4	3515	46,1	4020	57,1	5515	90,6
	32°C	1590	13,2	1620	13,5	1610	17,8	1975	21,9	2180	26,5	2590	31,5	3065	43,1	4200	67,1
	43°C	1105	10,5	1200	11,4	1150	11	1430	13,6	1525	18,8	2090	25,7	2440	31,7	3255	49,7

R404A

Ti: -18÷-25°C	IDK 750	IDK 1000	IDK 1250	IDK 1500	IDK 2000	IDK 2500	IDK 3000
	3	3	4	4	5	5	5
V/ph/Hz	400/3/50	400/3/50	400/3/50	400/3/50	400/3/50	400/3/50	400/3/50
kW	8,86	11,48	13,78	17,73	20,13	28,67	32,78
S	S	S	S	S	S	S	S
m³/h 50 Hz	38,64	48,8	56,95	73,2	83,9	110,6	126,7
m³/h 60 Hz	39,05	46,37	58,56	68,34	87,84	100,68	132,72
ER	ER	ER	ER	ER	ER	ER	ER
kW	7,6	7,6	10,1	11,1	12,1	16,9	16,9
kg	12	11	14	17	25	27	29

CONDENSATORE • CONDENSER • VERFLÜSSIGER • CONDENSADOR • CONDENSEUR • КОНДЕНСАТОР

mm	3,2	3,2	3,2	3,2	3,2	3,2	3,2
n°xØ mm	1x500	1x500	2x450	2x450	2x500	2x500	2x500
n°xW	1x540	1x540	2x390	2x390	2x540	2x540	2x750
m³/h	6450	6450	9800	9800	12900	12900	16600

EVAPORATORE • EVAPORATOR • VERDAMPFER • EVAPORADOR • EVAPORATEUR • ИСПАРИТЕЛЬ

mm	7	7	7	7	7	7	7
n°xØ mm	1x500	1x500	2x450	2x450	2x500	2x500	2x500
n°xW	1x750	1x750	2x450	2x450	2x750	2x750	2x750
m³/h	8300	8300	11400	11400	16600	16600	16600
m	20	20	19	19	22	22	22

TABELLA DI SELEZIONE • SELECTION TABLE • AUSWAHLTABELLE

TABLA DE SELECCION • TABLEAU DE SÉLECTION • ТАБЛИЦА ВЫБОРА

Ti	Ta	Q _o (W)	V (m³)	Q _o (W)	V (m³)	Q _o (W)	V (m³)	Q _o (W)	V (m³)	Q _o (W)	V (m³)	Q _o (W)	V (m³)	Q _o (W)	V (m³)
-18°C	20°C	11885	241	14285	415	16965	509	21420	675	24900	1001	31280	1483	34715	1740
	32°C	9560	149	11400	258	13540	325	17065	424	20130	645	26995	1018	30945	1247
	43°C	7595	134	8725	194	10365	239	13785	338	17340	509	23340	773	26775	965
-22°C	20°C	10405	185	12145	318	14420	408	18210	522	21445	793	26160	1127	31905	1486
	32°C	8170	137	9630	213	11435	261	14440	334	17470	517	23500	832	26940	1017
	43°C	6430	106	7260	147	8620	199	11520	289	13795	377	18660	574	22155	735
-25°C	20°C	9115	150	10775	273	12795	327	16155	432	19360	671	23805	957	27670	1205
	32°C	6935	111	8055	161	9565	227	12110	291	14440	396	19490	637	22340	784
	43°C	5400	82,5	5955	121	7075	167	9515	223	11530	305	15670	455	18610	584

R404A

T _i	-5÷+5°C		-18÷-25°C		IDQ 300	IDQ 500	IDQ 1000	IDQ 1500	IDQ 2000	IDQ 3000	
		1		2		1	2	3	4	5	5
	V/ph/Hz	400/3/50		400/3/50		400/3/50		400/3/50		400/3/50	
	kW	4,64		7,56		15,89		21,46		41,54	
		E		S		S		S		S	
	m ³ /h 50 Hz	14,9		22,72		48,8		73,2		126,7	
	m ³ /h 60 Hz	14,17		21,66		46,37		68,34		132,72	
		ER		ER		ER		ER		ER	
	kW	3,1		3,85		7,6		11,1		16,9	
	kg	3		6,5		11		18		28	

CONDENSATORE • CONDENSER • VERFLÜSSIGER • CONDENSADOR • CONDENSEUR • КОНДЕНСАТОР

	mm	3,2	3,2	3,2	3,2	3,2	3,2
	n°xØ mm	1x350	2x350	1x500	2x450	2x500	2x500
	n°xW	1x140	2x140	1x540	2x390	2x540	2x750
	m ³ /h	2450	4800	6450	9800	12900	16600

EVAPORATORE • EVAPORATOR • VERDAMPFER • EVAPORADOR • EVAPORATEUR • ИСПАРИТЕЛЬ

	mm	7	7	7	7	7	7
	n°xØ mm	1x350	2x350	1x500	2x450	2x500	2x500
	n°xW	1x140	2x140	1x750	2x450	2x750	2x750
	m ³ /h	2700	5200	8300	11400	16600	16600
	m	13	14	20	19	22	22

TABELLA DI SELEZIONE • SELECTION TABLE • AUSWAHLTABELLE

TABLA DE SELECCION • TABLEAU DE SÉLECTION • ТАБЛИЦА ВЫБОРА

T _i	T _a	Q _o (W)	V (m ³)	Q _o (W)	V (m ³)	Q _o (W)	V (m ³)	Q _o (W)	V (m ³)	Q _o (W)	V (m ³)	Q _o (W)	V (m ³)
-5°C	20°C	4470	69,9	5530	124	12185	256	19700	458	22618	526	32620	956
	32°C	3895	55,1	5155	108	9465	188	15400	312	17681	358	26445	718
	43°C	3045	38,2	4645	80,8	7230	136	12160	211	13961	242	20325	481
0°C	20°C	5960	105	8615	200	13395	291	22580	544	25924	625	36215	1140
	32°C	5425	89,6	7940	171	11400	234	18485	396	21223	455	31750	1012
	43°C	4325	65	7205	131	8410	162	14765	273	16952	313	24680	668
+5°C	20°C	7060	130	9745	229	16695	427	26885	681	30867	782	43065	1480
	32°C	6200	105	9150	207	13450	318	21755	495	24977	568	38155	1250
	43°C	5095	74,8	8530	178	10270	209	17780	351	20413	403	29715	907
-18°C	20°C	3120	45,5	6520	95,2	13945	385	19025	587	21843	674	35540	1042
	32°C	2315	32,9	5210	74,1	11160	269	15300	385	17566	442	28700	779
	43°C	1650	21,7	3890	51,2	7705	165	11525	285	13232	327	20475	485
-22°C	20°C	2590	36,6	5570	78,8	11900	290	16240	453	18645	520	30445	958
	32°C	1875	22,5	4410	52,9	8860	198	12180	313	13984	359	24295	774
	43°C	1290	13,9	3235	34,8	6345	135	9570	230	10987	264	17000	460
-25°C	20°C	2270	29,5	4995	64,8	10060	233	13770	356	15809	409	25855	889
	32°C	1605	15,6	3920	38,2	7830	159	10790	258	12388	296	20380	668
	43°C	1080	9,9	2845	26,1	5530	105	7850	173	9013	199	14920	455

R404A

Ti: -25÷-45°C	IDX 1000	IDX 1500	IDX 2500
	3	5	5
V/ph/Hz	400/3/50	400/3/50	400/3/50
kW	8,87	18,9	21,89
	SB	SB	SB
m³/h 50 Hz	45,9	95,3	110,5
m³/h 60 Hz	38,76	83,16	114,36
	ER	ER	ER
kW	7,6	16,9	16,9
kg	13	24	26

CONDENSATORE • CONDENSER • VERFLÜSSIGER • CONDENSADOR • CONDENSEUR • КОНДЕНСАТОР

mm	3,2	3,2	3,2
n°xØ mm	1x500	2x500	2x500
n°xW	1x540	2x540	2x750
m³/h	6450	12900	16600

EVAPORATORE • EVAPORATOR • VERDAMPFER • EVAPORADOR • EVAPORATEUR • ИСПАРИТЕЛЬ

mm	7	7	7
n°xØ mm	1x500	2x500	2x500
n°xW	1x750	2x750	2x750
m³/h	8300	16600	16600
m	20	22	22

TABELLA DI SELEZIONE • SELECTION TABLE • AUSWAHLTABELLE

TABLA DE SELECCION • TABLEAU DE SÉLECTION • ТАБЛИЦА ВЫБОРА

Ti	Ta	Q _o (W)	Q _o (W)	Q _o (W)
	20°C	8720	13840	20910
-25°C	32°C	8240	12800	19910
	43°C	7790	11960	14750
	20°C	6330	10330	14780
-35°C	32°C	5960	9400	13900
	43°C	5610	8790	13020
	20°C	4230	6960	10680
-45°C	32°C	3960	6310	9880
	43°C	3680	5870	9350

1

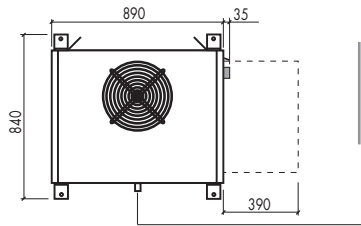
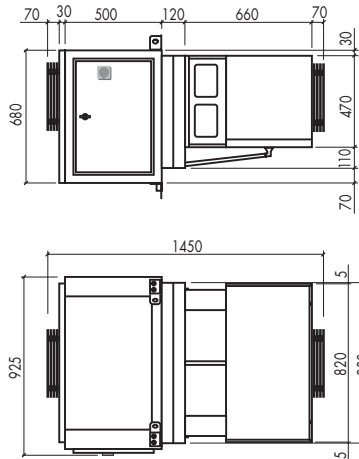

Tubo scarico condensa
 Condensate drain pipe
 Kondenswasserabflußrohr
 Tubo de desagüe del condensado
 Tuyau écoulement eau
 Трубка слива талой воды

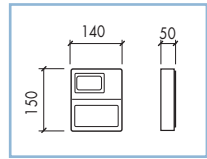

FORO PARETE CELLA
 COLD ROOM WALL HOLE
 WANDAUSCHNITT
 ORIFICIO PARED CAMARA
 TROU PAROI CHAMBRE FROIDE
 ОТВЕРСТИЕ В СТЕНЕ КАМЕРЫ
b= 840mm h= 585mm

2

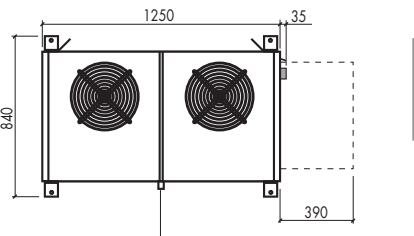
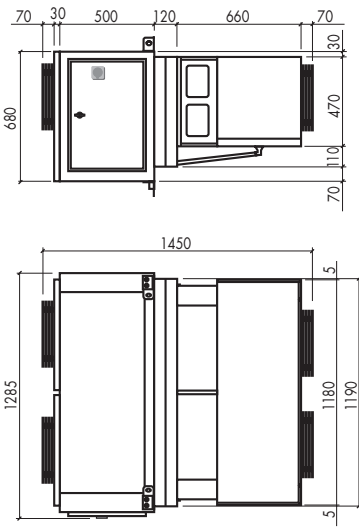

Tubo scarico condensa
 Condensate drain pipe
 Kondenswasserabflußrohr
 Tubo de desagüe del condensado
 Tuyau écoulement eau
 Трубка слива талой воды

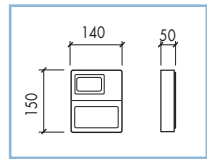

FORO PARETE CELLA
 COLD ROOM WALL HOLE
 WANDAUSCHNITT
 ORIFICIO PARED CAMARA
 TROU PAROI CHAMBRE FROIDE
 ОТВЕРСТИЕ В СТЕНЕ КАМЕРЫ
b=1200mm h= 585mm

3

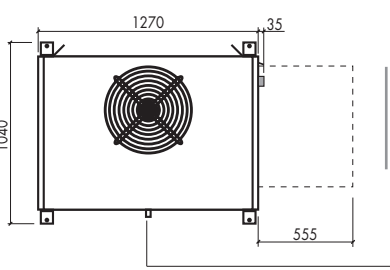
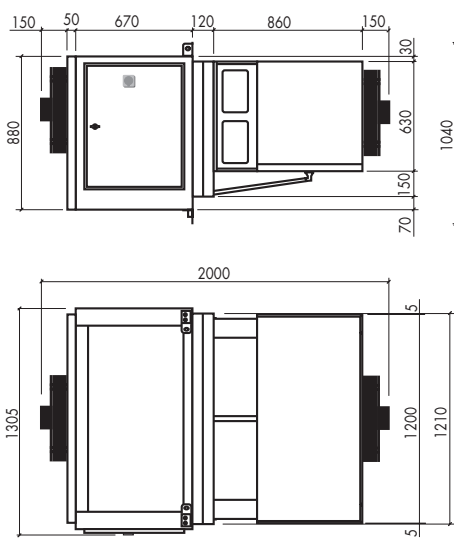

Tubo scarico condensa
 Condensate drain pipe
 Kondenswasserabflußrohr
 Tubo de desagüe del condensado
 Tuyau écoulement eau
 Трубка слива талой воды

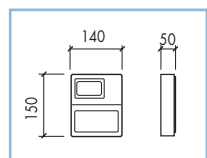

FORO PARETE CELLA
 COLD ROOM WALL HOLE
 WANDAUSCHNITT
 ORIFICIO PARED CAMARA
 TROU PAROI CHAMBRE FROIDE
 ОТВЕРСТИЕ В СТЕНЕ КАМЕРЫ
b=1220mm h= 785mm

4

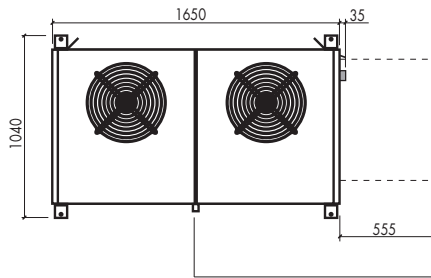
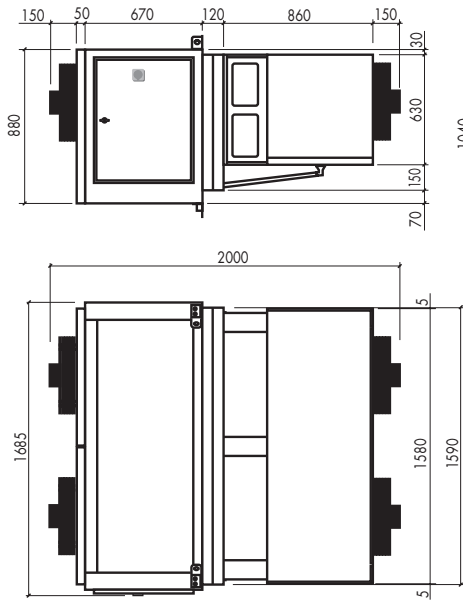

Tubo scarico condensa
 Condensate drain pipe
 Kondenswasserabflußrohr
 Tubo de desagüe del condensado
 Tuyau écoulement eau
 Трубка слива талой воды

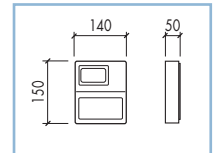

FORO PARETE CELLA
 COLD ROOM WALL HOLE
 WANDAUSCHNITT
 ORIFICIO PARED CAMARA
 TROU PAROI CHAMBRE FROIDE
 ОТВЕРСТИЕ В СТЕНЕ КАМЕРЫ
b= 1600mm h= 785mm

b

5

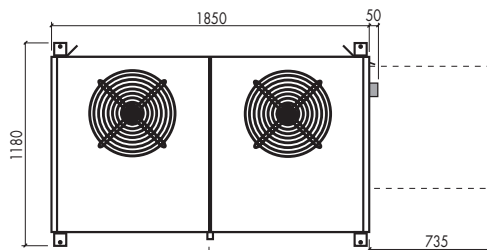
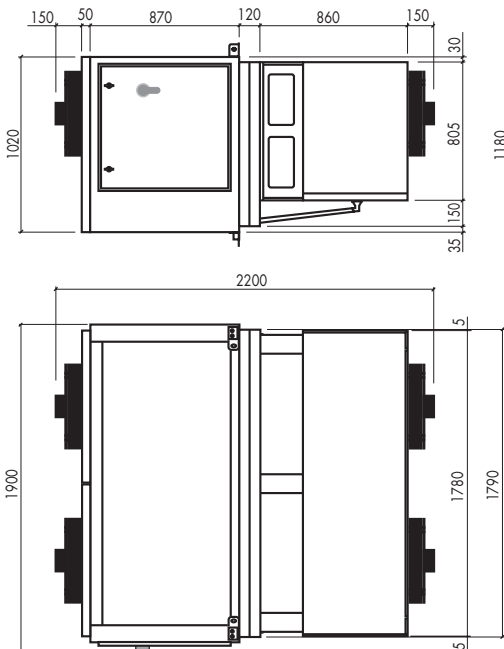

Tubo scarico condensa
 Condensate drain pipe
 Kondenswasserabflußrohr
 Tubo de desagüe del condensado
 Tuyau écoulement eau
 Трубка слива талой воды

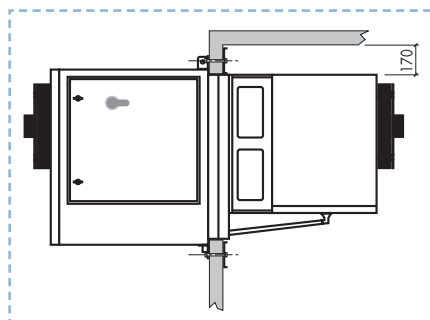

FORO PARETE CELLA
 COLD ROOM WALL HOLE
 WANDAUSCHNITT
 ORIFICIO PARED CAMARA
 TROU PAROI CHAMBRE FROIDE
 ОТВЕРСТИЕ В СТЕНЕ КАМЕРЫ
b=1800mm h= 960mm

b